

### SPECIFICATIONS

- UNIVERSAL 6-IN-1 LATCH: DRIVE IN, SQUARE MORTISE AND RADIUS CORNER WITH ADJUSTABLE BACKSET: 2-3/8" (60 mm) - 2-3/4" (70 mm)
- STANDARD BORE HOLES: 2-1/8" (54 mm)
- FITS STANDARD DOOR THICKNESS: 1-3/8" (35 mm) - 1-3/4" (45 mm)
- FULL LIP RADIUS CORNER STRIKE WITH ADJUSTABLE TAB STANDARD: 1-3/4" x 2-1/4" (45 mm x 57 mm)
- EASY ACCESS EXPOSED DUAL SCREWS (ONE SIDE)
- PUSH BUTTON AUTO-RELEASE ON PRIVACY FUNCTION
- TURN BUTTON AUTO-RELEASE ON ENTRY FUNCTION
- NON-FIRE RATED



GRADE  
**3**

ANSI GRADE 3



LIFETIME MECHANICAL & 5 YEAR FINISH WARRANTY

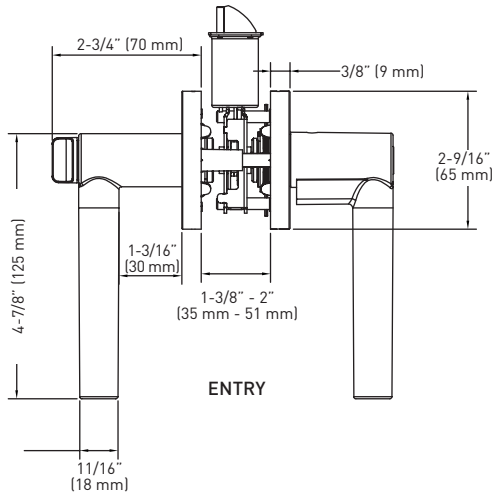

ENTRY

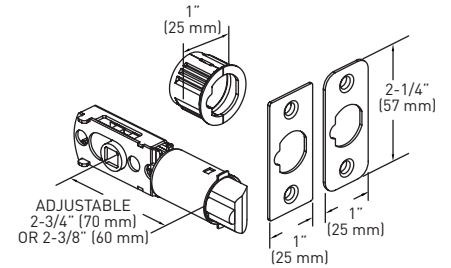

6-IN-1 ENTRY LATCH

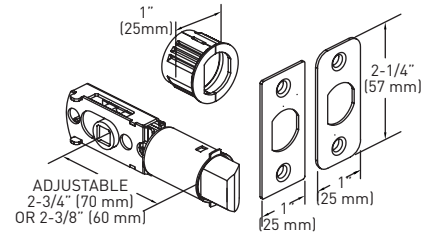

6-IN-1 PRIVACY/PASSAGE LATCH

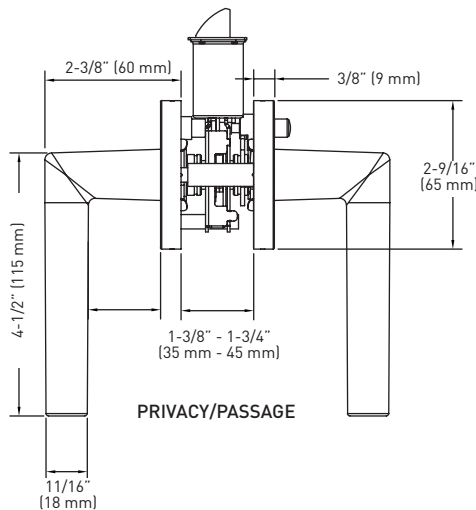

PRIVACY/PASSAGE

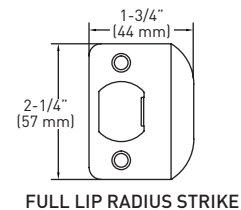

FULL LIP RADIUS STRIKE

MEASUREMENTS SUBJECT TO A 3% VARIANCE

MEASUREMENTS ARE FOR REFERENCE ONLY. TAYMOR RESERVES THE RIGHT TO CHANGE THE PRODUCT SPECS WITHOUT NOTICE. FOR PRODUCT WARRANTY, PLEASE VISIT TAYMOR WEBSITE FOR DETAILS

BUILDER PACK	ENTRY	PRIVACY	PASSAGE	DUMMY	CASE QTY.
SATIN NICKEL 15	33-D009064SN	33-D009024SN	33-D009034SN	33-904SN	20
MATTE BLACK 19	33-D009064BLK	33-D009024BLK	33-D009034BLK	33-904BLK	20
POLISHED CHROME 26	33-D009064PC	33-D009024PC	33-D009034PC	33-904PC	20
<b>RETAIL PACK</b>					
SATIN NICKEL 15	34-FV009064SN	34-FV009024SN	34-FV009034SN	-	4

